



VNB14NV04/VND14NV04 VND14NV04-1/VNP14NV04/VNS14NV04

“OMNIFET II”: FULLY AUTOPROTECTED POWER MOSFET

TYPE	R _{DS(on)}	I _{lim}	V _{clamp}
VNB14NV04	35 mΩ	12 A	40 V
VND14NV04			
VND14NV04-1			
VNP14NV04			
VNS14NV04			

- LINEAR CURRENT LIMITATION
- THERMAL SHUT DOWN
- SHORT CIRCUIT PROTECTION
- INTEGRATED CLAMP
- LOW CURRENT DRAWN FROM INPUT PIN
- DIAGNOSTIC FEEDBACK THROUGH INPUT PIN
- ESD PROTECTION
- DIRECT ACCESS TO THE GATE OF THE POWER MOSFET (ANALOG DRIVING)
- COMPATIBLE WITH STANDARD POWER MOSFET

DESCRIPTION

The VNB14NV04, VND14NV04, VND14NV04-1, VNP14NV04, VNS14NV04, are monolithic devices designed in STMicroelectronics VIPower M0-3 Technology, intended for replacement of standard Power MOSFETS from DC up to 50KHz

BLOCK DIAGRAM

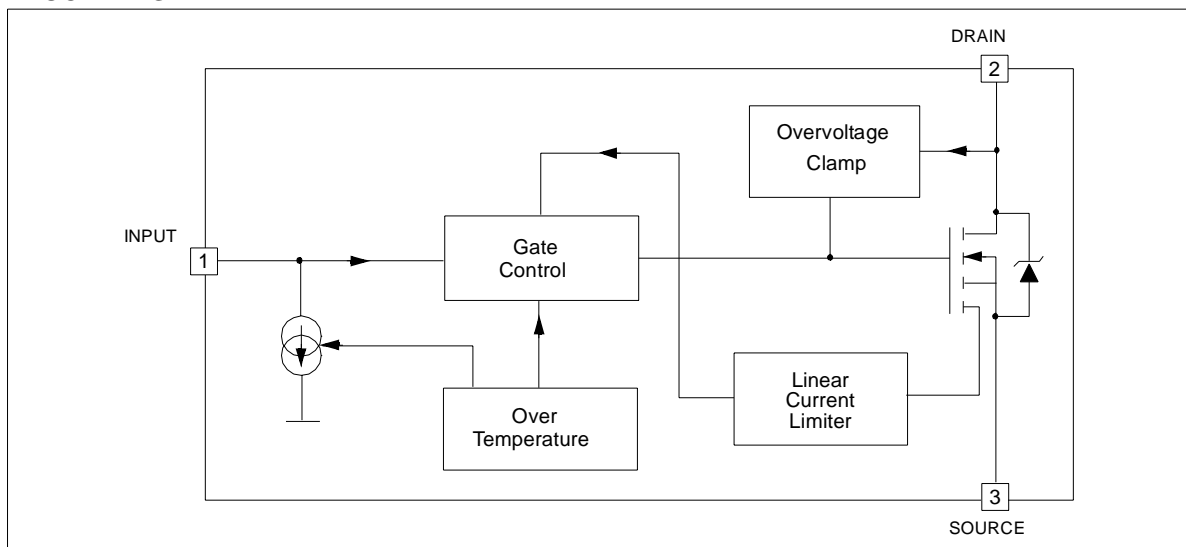



TO-252 (DPAK)



SO-8



TO-220

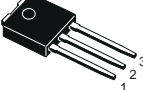

TO-251 (IPAK)

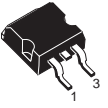

D²PAK

ORDER CODES		
PACKAGE	TUBE	T&R
D ² PAK	VNB14NV04	VNB14NV0413TR
TO-252 (DPAK)	VND14NV04	VND14NV0413TR
TO-251 (IPAK)	VND14NV04-1	-
TO-220	VNP14NV04	-
SO-8	VNS14NV04	-

applications. Built in thermal shutdown, linear current limitation and overvoltage clamp protect the chip in harsh environments.

Fault feedback can be detected by monitoring the voltage at the input pin.

ABSOLUTE MAXIMUM RATING

Symbol	Parameter	Value					Unit
		SO-8	DPAK	TO-220	IPAK	D ² PAK	
V _{DS}	Drain-source Voltage (V _{IN} =0V)	Internally Clamped					V
V _{IN}	Input Voltage	Internally Clamped					V
I _{IN}	Input Current	+/-20					mA
R _{INMIN}	Minimum Input Series Impedance	10					Ω
I _D	Drain Current	Internally Limited					A
I _R	Reverse DC Output Current	-15					A
V _{ESD1}	Electrostatic Discharge (R=1.5KΩ, C=100pF)	4000					V
V _{ESD2}	Electrostatic Discharge on output pin only (R=330Ω, C=150pF)	16500					V
P _{tot}	Total Dissipation at T _c =25°C	4.6	74	74	74	74	W
E _{MAX}	Maximum Switching Energy (L=0.4mH; R _L =0Ω; V _{bat} =13.5V; T _{jstart} =150°C; I _L =18A)		93			93	mJ
T _j	Operating Junction Temperature	Internally limited					°C
T _c	Case Operating Temperature	Internally limited					°C
T _{stg}	Storage Temperature	-55 to 150					°C

CONNECTION DIAGRAM (TOP VIEW)

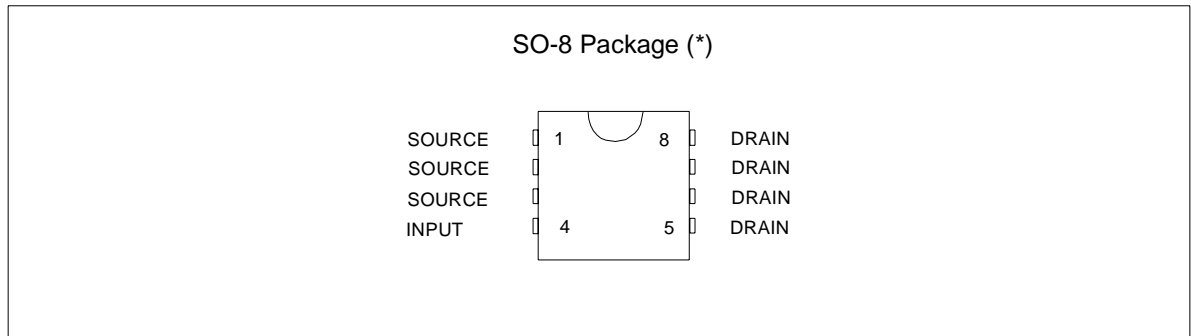

(*) For the pins configuration related to DPAK, D²PAK, IPAk, TO-220 see outlines at page 1.

CURRENT AND VOLTAGE CONVENTIONS

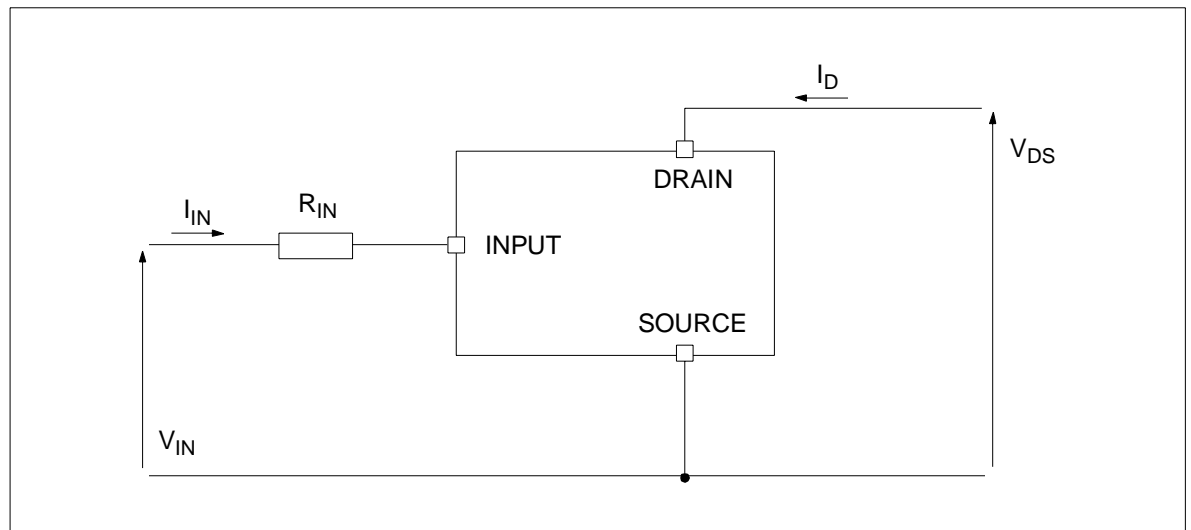

VNB14NV04 / VND14NV04 / VND14NV04-1 / VNP14NV04 / VNS14NV04

THERMAL DATA

Symbol	Parameter	Value					Unit
		SO-8	DPAK	TO-220	IPAK	D ² PAK	
R _{thj-case}	Thermal Resistance Junction-case MAX		1.7	1.7	1.7	1.7	°C/W
R _{thj-lead}	Thermal Resistance Junction-lead MAX	27					°C/W
R _{thj-amb}	Thermal Resistance Junction-ambient MAX	90 (*)	65 (*)	62	102	52 (*)	°C/W

(*) When mounted on a standard single-sided FR4 board with 0.5cm² of Cu (at least 35 μm thick) connected to all DRAIN pins. Horizontal mounting and no artificial air flow.

ELECTRICAL CHARACTERISTICS (-40°C < T_j < 150°C, unless otherwise specified)

OFF

Symbol	Parameter	Test Conditions	Min	Typ	Max	Unit
V _{CLAMP}	Drain-source Clamp Voltage	V _{IN} =0V; I _D =7A	40	45	55	V
V _{CLTH}	Drain-source Clamp Threshold Voltage	V _{IN} =0V; I _D =2mA	36			V
V _{INTH}	Input Threshold Voltage	V _{DS} =V _{IN} ; I _D =1mA	0.5		2.5	V
I _{ISS}	Supply Current from Input Pin	V _{DS} =0V; V _{IN} =5V		100	150	μA
V _{INCL}	Input-Source Clamp Voltage	I _{IN} =1mA I _{IN} =-1mA	6 -1.0	6.8	8 -0.3	V
I _{DSS}	Zero Input Voltage Drain Current (V _{IN} =0V)	V _{DS} =13V; V _{IN} =0V; T _j =25°C V _{DS} =25V; V _{IN} =0V			30 75	μA

ON

Symbol	Parameter	Test Conditions	Min	Typ	Max	Unit
R _{DS(on)}	Static Drain-source On Resistance	V _{IN} =5V; I _D =7A; T _j =25°C V _{IN} =5V; I _D =7A			35 70	mΩ

VNB14NV04 / VND14NV04 / VND14NV04-1 / VNP14NV04 / VNS14NV04

ELECTRICAL CHARACTERISTICS (continued) ($T_j=25^\circ\text{C}$, unless otherwise specified)

DYNAMIC

Symbol	Parameter	Test Conditions	Min	Typ	Max	Unit
g_{fs}^*	Forward Transconductance	$V_{DD}=13\text{V}; I_D=7\text{A}$		18		S
C_{OSS}	Output Capacitance	$V_{DS}=13\text{V}; f=1\text{MHz}; V_{IN}=0\text{V}$		400		pF

SWITCHING

Symbol	Parameter	Test Conditions	Min	Typ	Max	Unit
$t_{d(on)}$	Turn-on Delay Time	$V_{DD}=15\text{V}; I_D=7\text{A}$		80	250	ns
t_r	Rise Time			350	1000	ns
$t_{d(off)}$	Turn-off Delay Time	$V_{gen}=5\text{V}; R_{gen}=R_{IN\ MIN}=10\Omega$ (see figure 1)		450	1350	ns
t_f	Fall Time			150	500	ns
$t_{d(on)}$	Turn-on Delay Time	$V_{DD}=15\text{V}; I_D=7\text{A}$		1.5	4.5	μs
t_r	Rise Time			9.7	30.0	μs
$t_{d(off)}$	Turn-off Delay Time	$V_{gen}=5\text{V}; R_{gen}=2.2\text{K}\Omega$ (see figure 1)		9	25.0	μs
t_f	Fall Time			10.2	30.0	μs
$(di/dt)_{on}$	Turn-on Current Slope	$V_{DD}=15\text{V}; I_D=7\text{A}$ $V_{gen}=5\text{V}; R_{gen}=R_{IN\ MIN}=10\Omega$		16		$\text{A}/\mu\text{s}$
Q_i	Total Input Charge	$V_{DD}=12\text{V}; I_D=7\text{A}; V_{IN}=5\text{V}; I_{gen}=2.13\text{mA}$ (see figure 5)		36.8		nC

SOURCE DRAIN DIODE

Symbol	Parameter	Test Conditions	Min	Typ	Max	Unit
V_{SD}^*	Forward On Voltage	$I_{SD}=7\text{A}; V_{IN}=0\text{V}$		0.8		V
t_{rr}	Reverse Recovery Time	$I_{SD}=7\text{A}; di/dt=40\text{A}/\mu\text{s}$		300		ns
Q_{rr}	Reverse Recovery Charge	$V_{DD}=30\text{V}; L=200\mu\text{H}$		0.8		μC
I_{RRM}	Reverse Recovery Current	(see test circuit, figure 2)		5		A

PROTECTIONS ($-40^\circ\text{C} < T_j < 150^\circ\text{C}$, unless otherwise specified)

Symbol	Parameter	Test Conditions	Min	Typ	Max	Unit
I_{lim}	Drain Current Limit	$V_{IN}=5\text{V}; V_{DS}=13\text{V}$	12	18	24	A
t_{dim}	Step Response Current Limit	$V_{IN}=5\text{V}; V_{DS}=13\text{V}$		45		μs
T_{jsh}	Overtemperature Shutdown		150	175	200	$^\circ\text{C}$
T_{jrs}	Overtemperature Reset		135			$^\circ\text{C}$
I_{gf}	Fault Sink Current	$V_{IN}=5\text{V}; V_{DS}=13\text{V}; T_j=T_{jsh}$	10	15	20	mA
E_{as}	Single Pulse Avalanche Energy	starting $T_j=25^\circ\text{C}; V_{DD}=24\text{V}$ $V_{IN}=5\text{V}; R_{gen}=R_{IN\ MIN}=10\Omega; L=24\text{mH}$ (see figures 3 & 4)	400			mJ

(*) Pulsed: Pulse duration = 300 μs , duty cycle 1.5%

PROTECTION FEATURES

During normal operation, the INPUT pin is electrically connected to the gate of the internal power MOSFET through a low impedance path.

The device then behaves like a standard power MOSFET and can be used as a switch from DC up to 50KHz. The only difference from the user's standpoint is that a small DC current I_{SS} (typ. 100 μ A) flows into the INPUT pin in order to supply the internal circuitry.

The device integrates:

- OVERVOLTAGE CLAMP PROTECTION:

internally set at 45V, along with the rugged avalanche characteristics of the Power MOSFET stage give this device unrivalled ruggedness and energy handling capability. This feature is mainly important when driving inductive loads.

- LINEAR CURRENT LIMITER CIRCUIT:

limits the drain current I_D to I_{lim} whatever the INPUT pin voltages. When the current limiter is active, the device operates in the linear region, so power dissipation may exceed the capability of the heatsink. Both case and junction temperatures increase, and if this phase lasts long enough, junction temperature may reach the overtemperature threshold T_{jsh} .

- OVERTEMPERATURE AND SHORT CIRCUIT PROTECTION:

these are based on sensing the chip temperature and are not dependent on the input voltage. The location of the sensing element on the chip in the power stage area ensures fast, accurate detection of the junction temperature. Overtemperature cutout occurs in the range 150 to 190 °C, a typical value being 170 °C. The device is automatically restarted when the chip temperature falls of about 15°C below shut-down temperature.

- STATUS FEEDBACK:

in the case of an overtemperature fault condition ($T_j > T_{jsh}$), the device tries to sink a diagnostic current I_{gf} through the INPUT pin in order to indicate fault condition. If driven from a low impedance source, this current may be used in order to warn the control circuit of a device shutdown. If the drive impedance is high enough so that the INPUT pin driver is not able to supply the current I_{gf} , the INPUT pin will fall to 0V. **This will not however affect the device operation: no requirement is put on the current capability of the INPUT pin driver except to be able to supply the normal operation drive current I_{SS} .**

Additional features of this device are ESD protection according to the Human Body model and the ability to be driven from a TTL Logic circuit.

Figure 1: Switching Time Test Circuit for Resistive Load

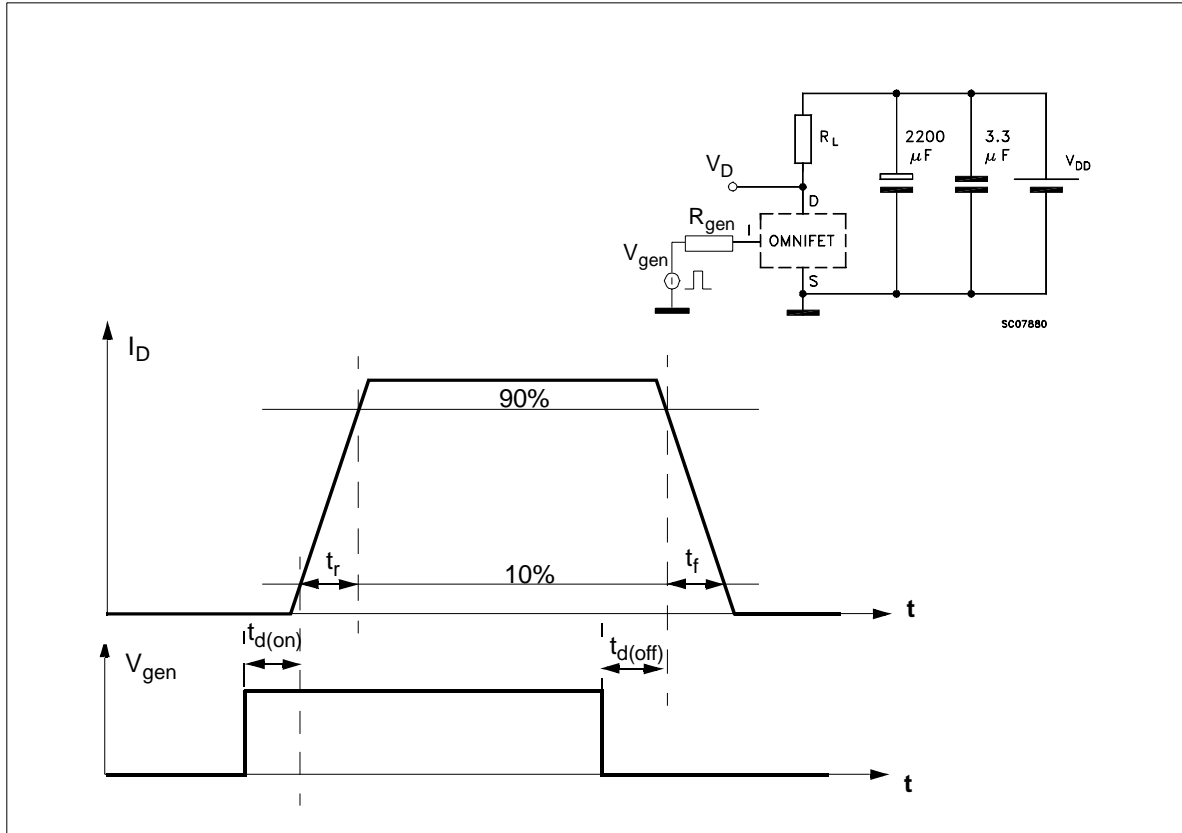

Figure 2: Test Circuit for Diode Recovery Times

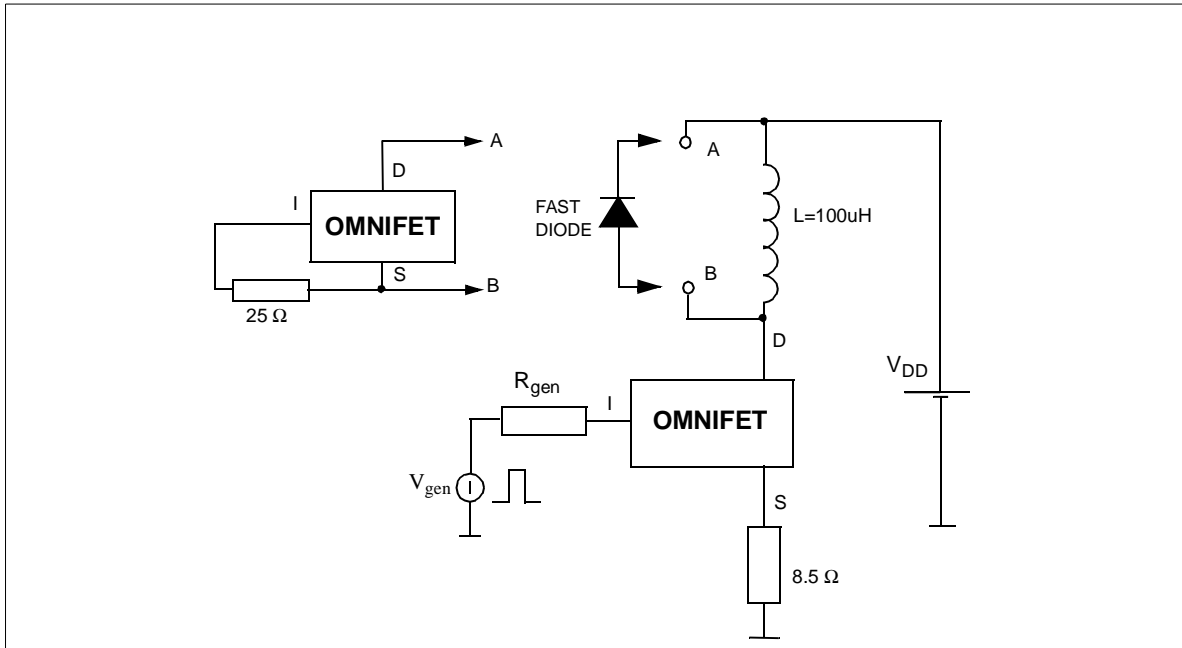

Figure 3: Unclamped Inductive Load Test Circuits

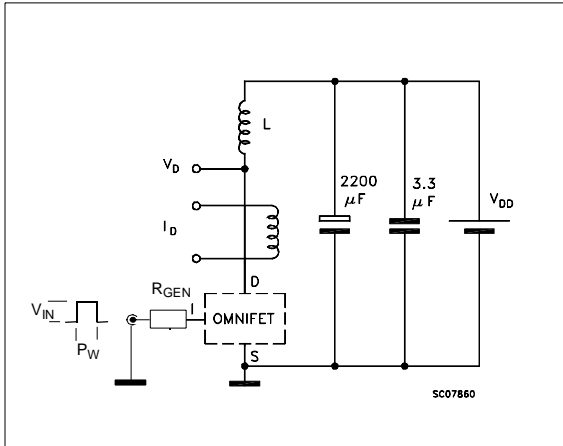

Figure 4: Unclamped Inductive Waveforms

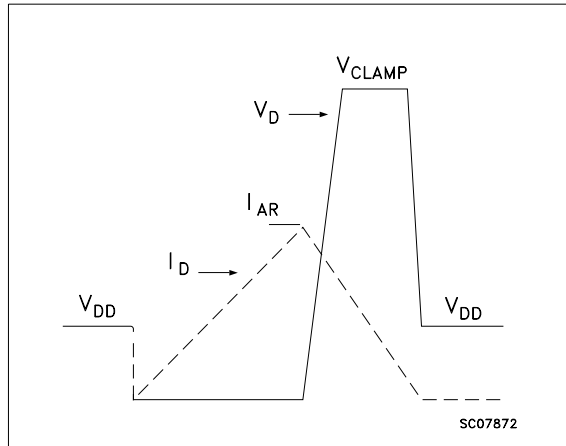
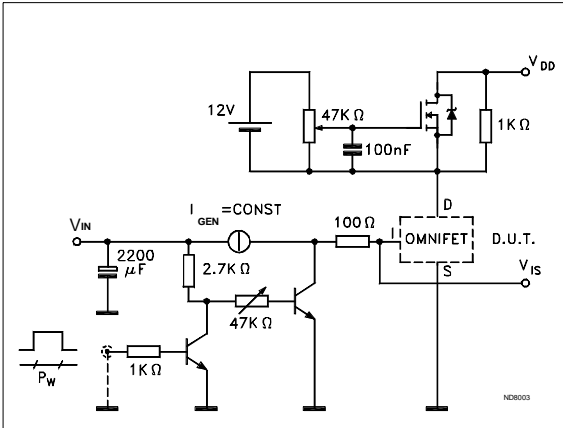
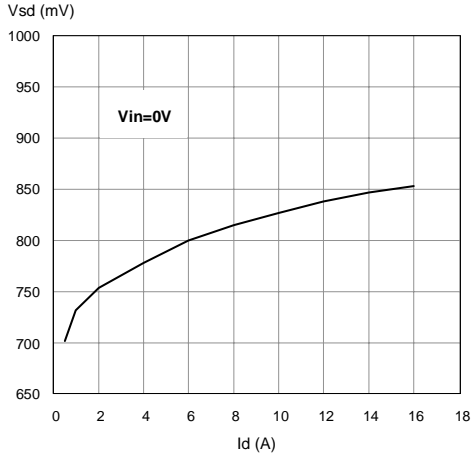

Figure 5: Input Charge Test Circuit



Source-Drain Diode Forward Characteristics



Static Drain Source On Resistance

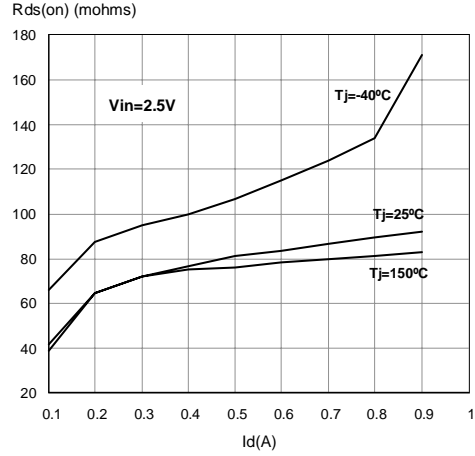

Derating Curve

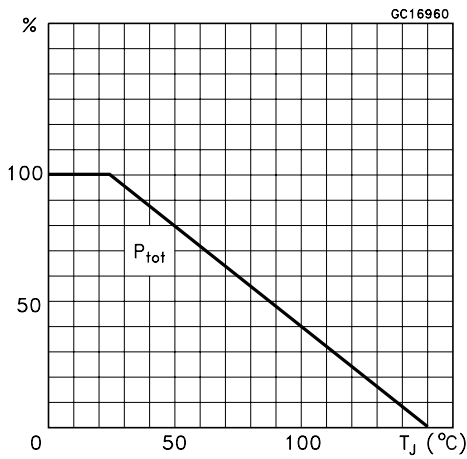

Static Drain-Source On resistance Vs. Input Voltage

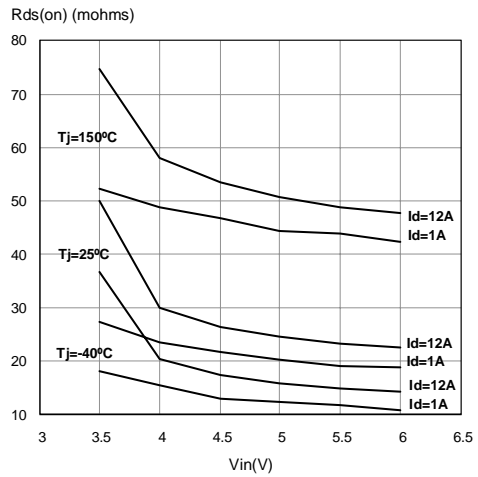

Static Drain-Source On resistance Vs. Input Voltage

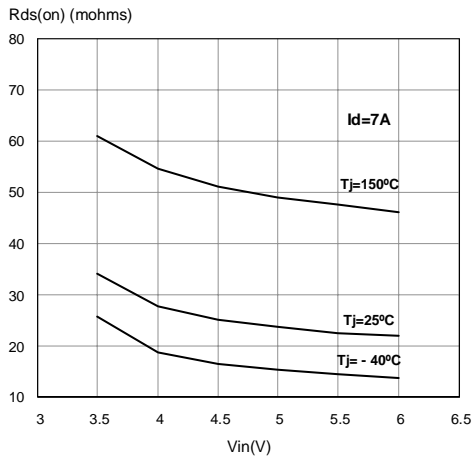

Transconductance

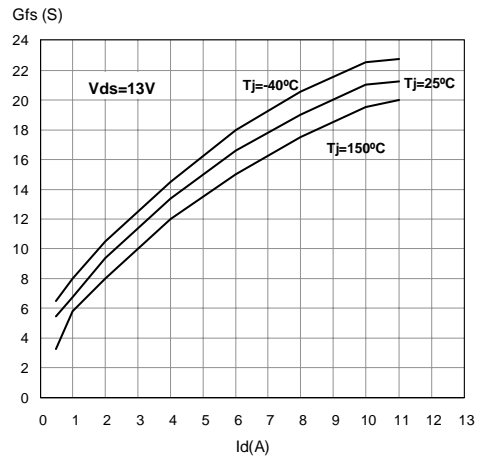

Static Drain-Source On Resistance Vs. Id

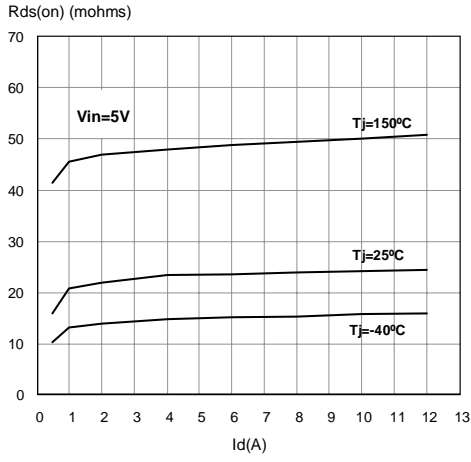

Transfer Characteristics

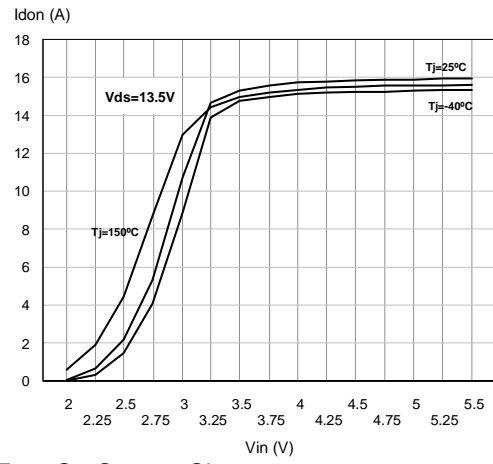

Turn On Current Slope

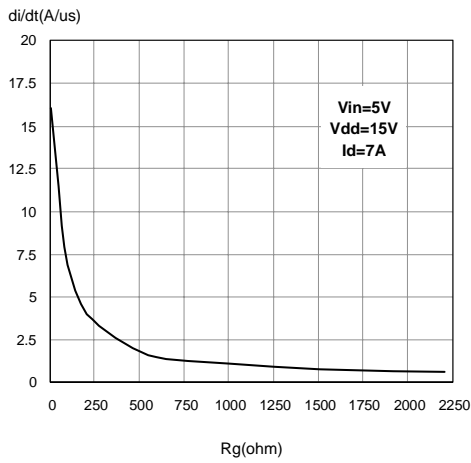

Turn On Current Slope

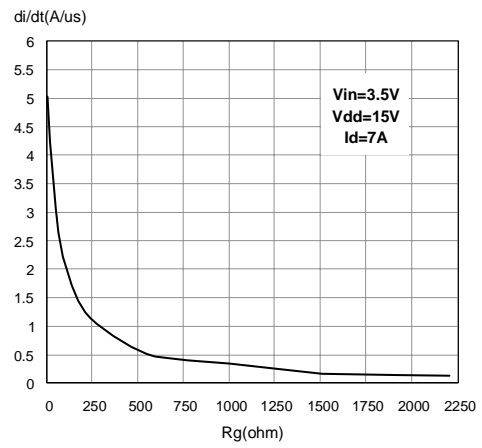

Input Voltage Vs. Input Charge

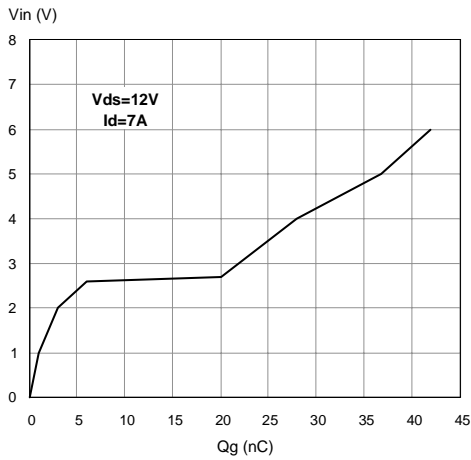

Turn off drain source voltage slope

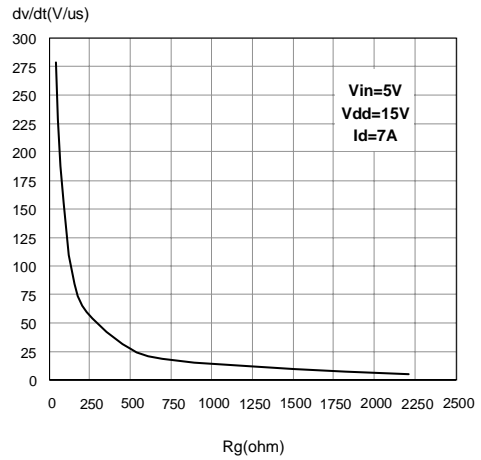

Turn Off Drain-Source Voltage Slope

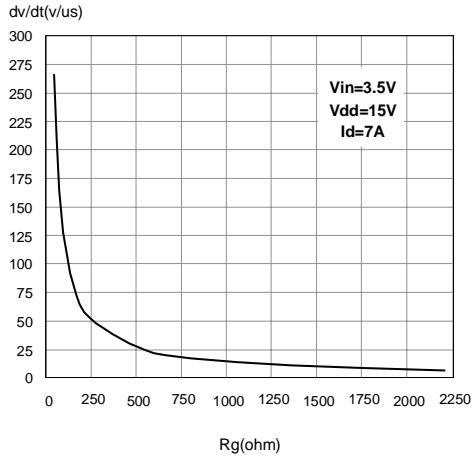

Capacitance Variations

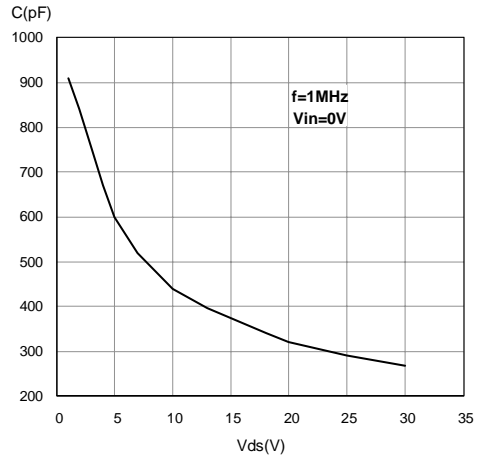

Switching Time Resistive Load

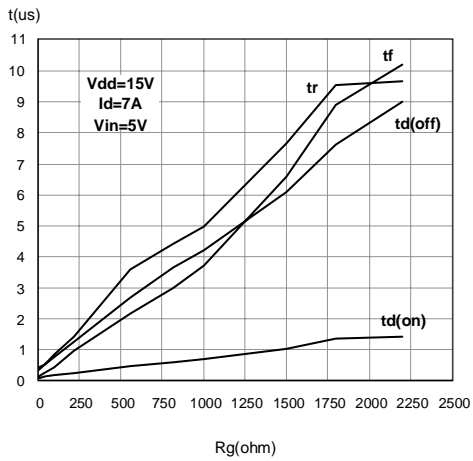

Switching Time Resistive Load

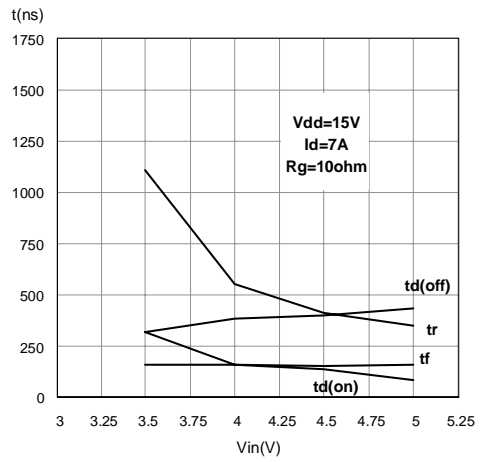

Output Characteristics

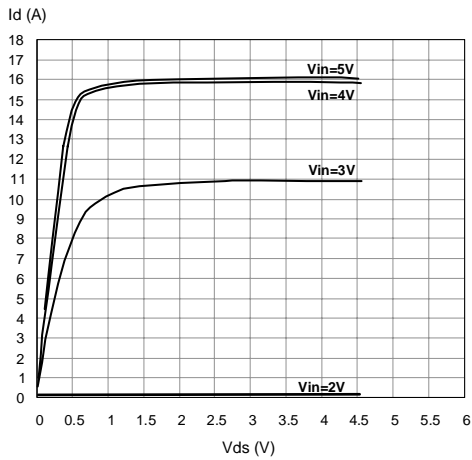

Normalized On Resistance Vs. Temperature

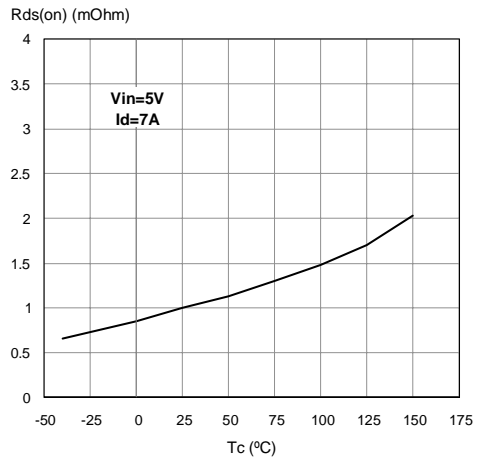

Normalized Input Threshold Voltage Vs. Current Limit Vs. Junction Temperature

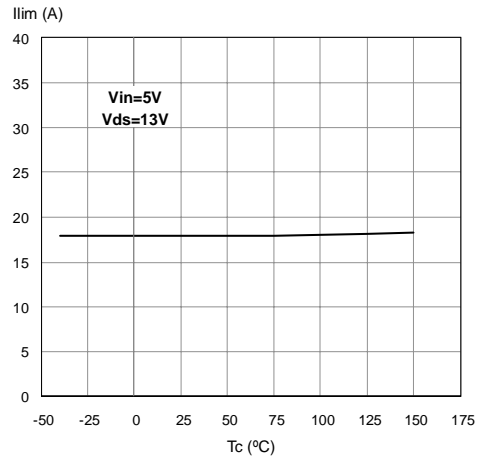
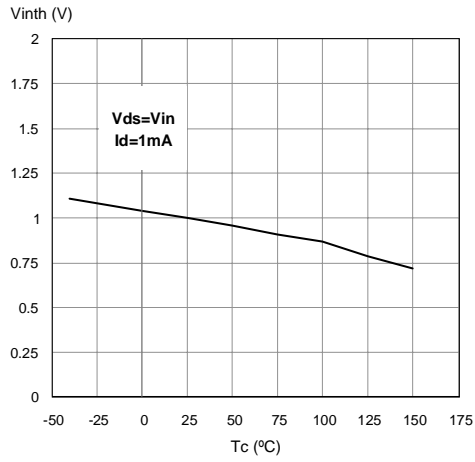

Step Response Current Limit

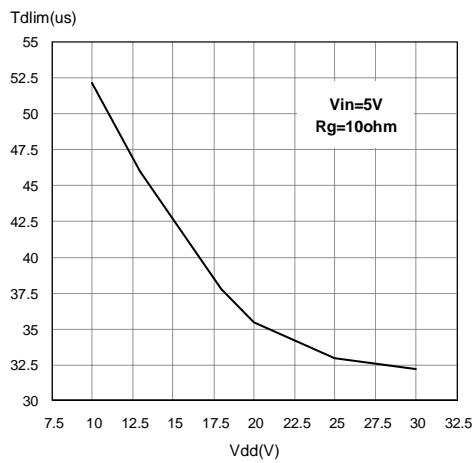

DPAK Maximum turn off current versus load inductance

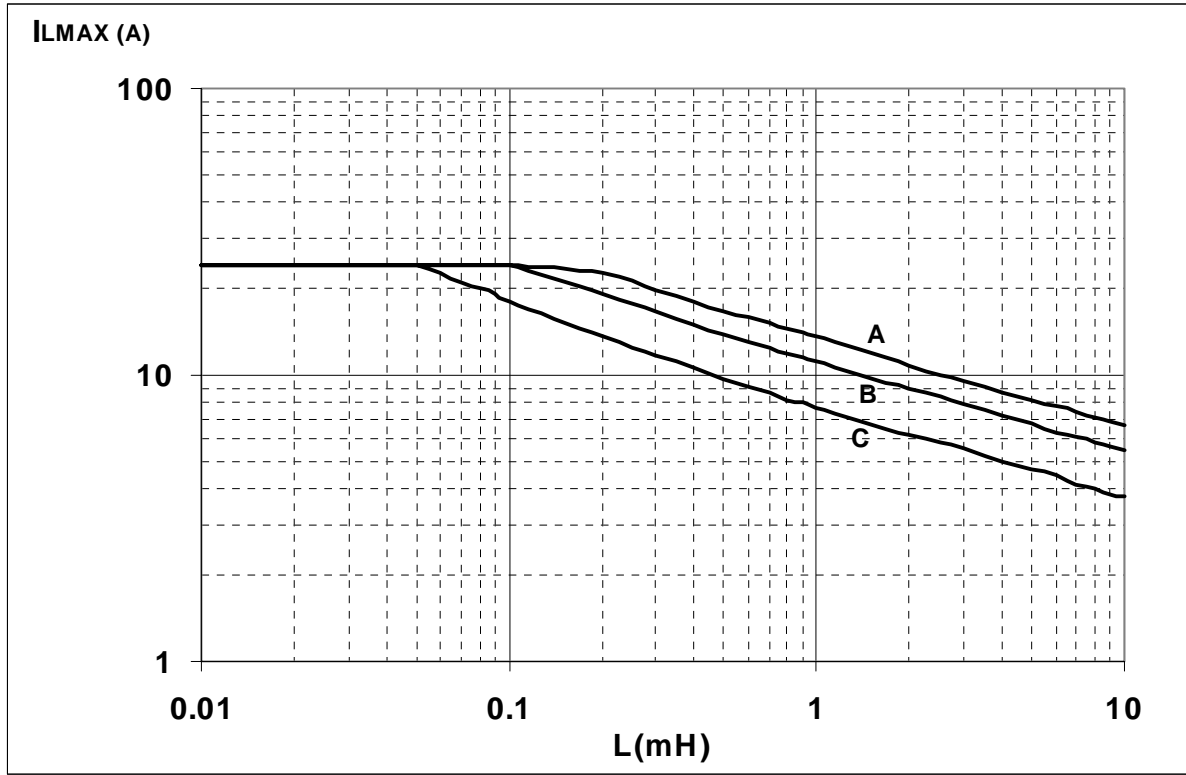

- A = Single Pulse at $T_{Jstart}=150^{\circ}C$
- B = Repetitive pulse at $T_{Jstart}=100^{\circ}C$
- C = Repetitive Pulse at $T_{Jstart}=125^{\circ}C$

Conditions:

$V_{CC}=13.5V$

Values are generated with $R_L=0\Omega$

In case of repetitive pulses, T_{Jstart} (at beginning of each demagnetization) of every pulse must not exceed the temperature specified above for curves B and C.

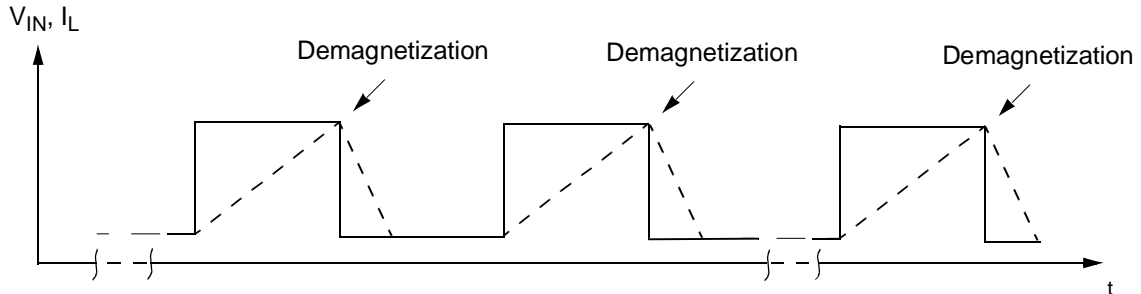

D²PAK Maximum turn off current versus load inductance

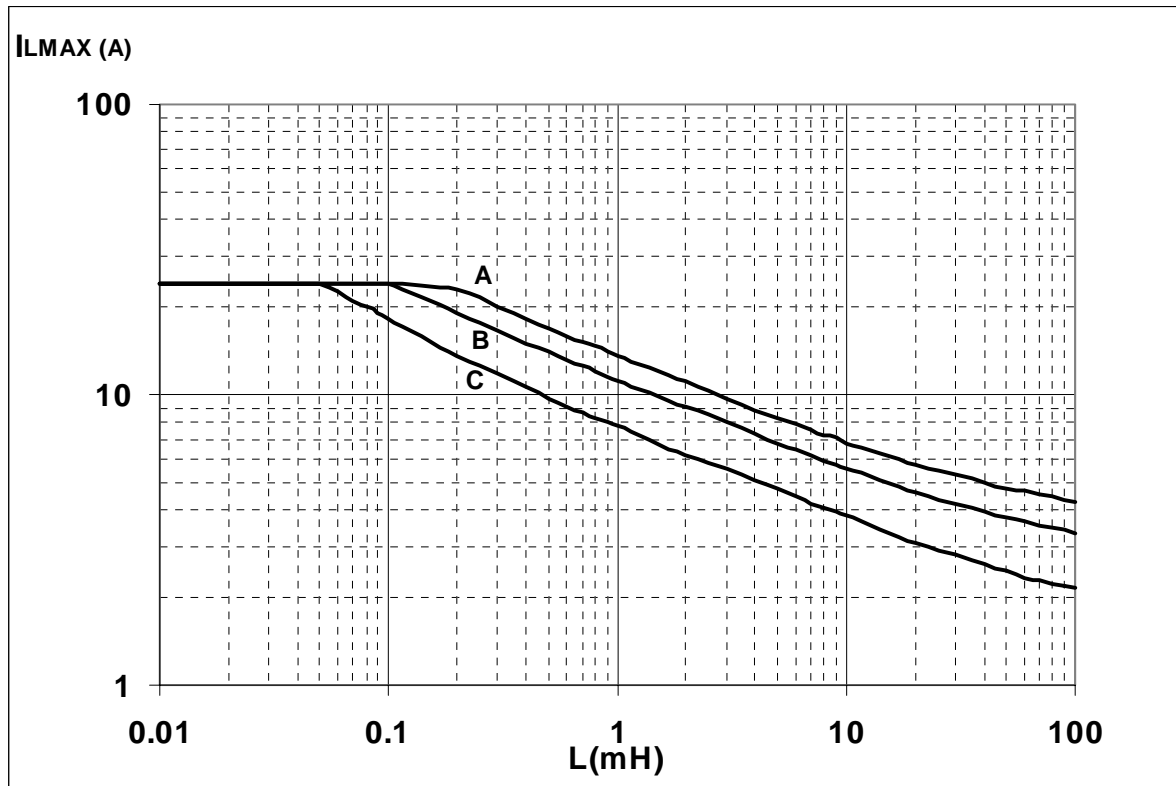

- A = Single Pulse at $T_{jstart}=150^{\circ}C$
- B = Repetitive pulse at $T_{jstart}=100^{\circ}C$
- C = Repetitive Pulse at $T_{jstart}=125^{\circ}C$

Conditions:

$V_{CC}=13.5V$

Values are generated with $R_L=0\Omega$

In case of repetitive pulses, T_{jstart} (at beginning of each demagnetization) of every pulse must not exceed the temperature specified above for curves B and C.

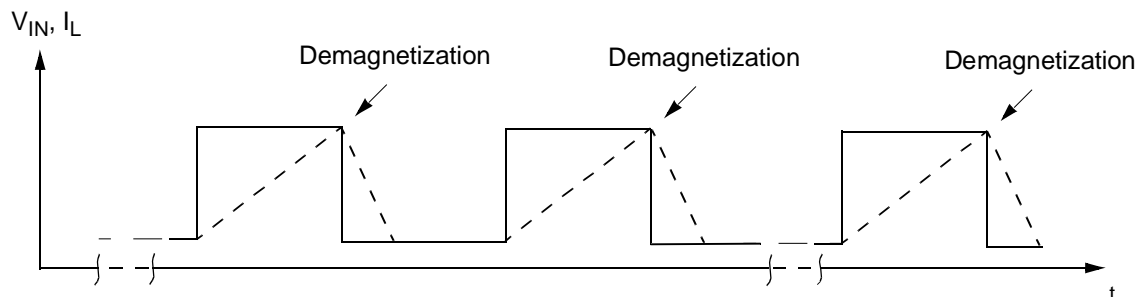

DPAK THERMAL DATA

DPAK PC Board

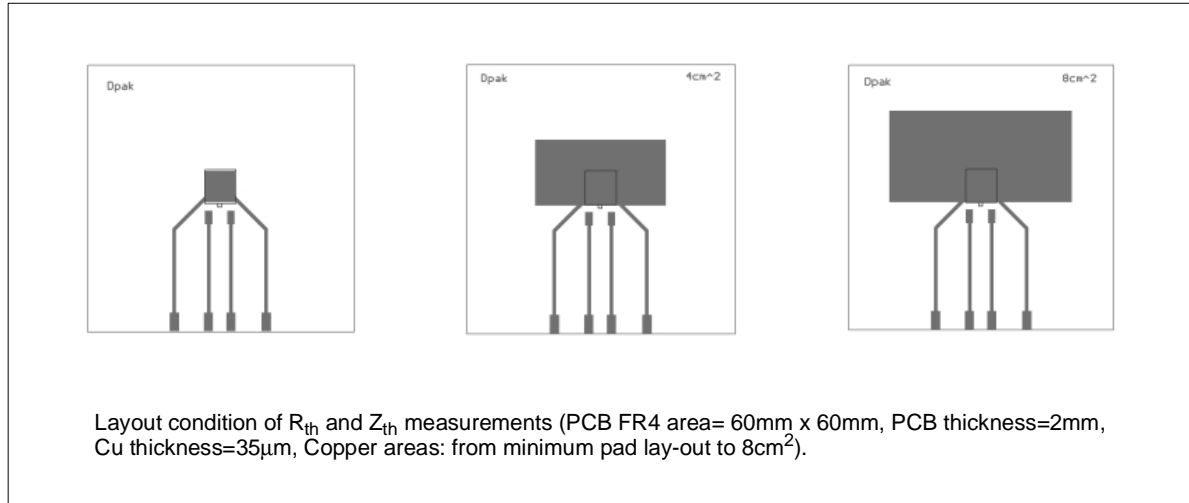

$R_{thj-amb}$ Vs PCB copper area in open box free air condition

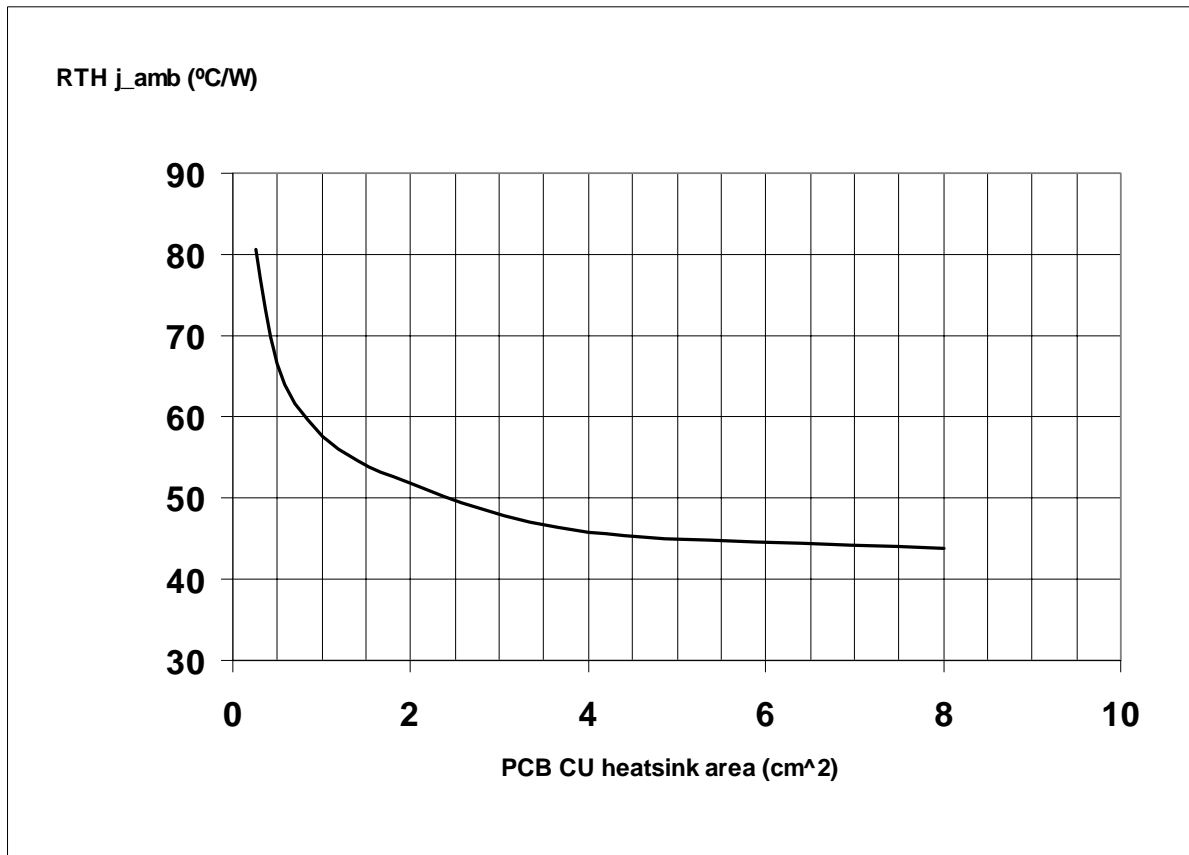

SO-8 THERMAL DATA

SO-8 PC Board

UNSxNU04 0.14cm²



UNSxNU04 0.6cm²



UNSxNU04 1.6cm²

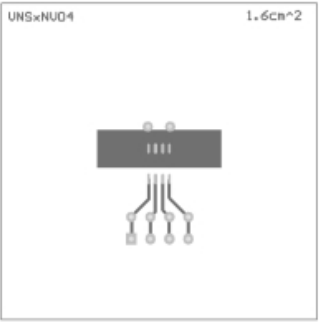

Layout condition of R_{th} and Z_{th} measurements (PCB FR4 area= 58mm x 58mm, PCB thickness=2mm, Cu thickness=35 μ m, Copper areas: 0.14cm², 0.6cm², 1.6cm²).

$R_{thj-amb}$ Vs PCB copper area in open box free air condition

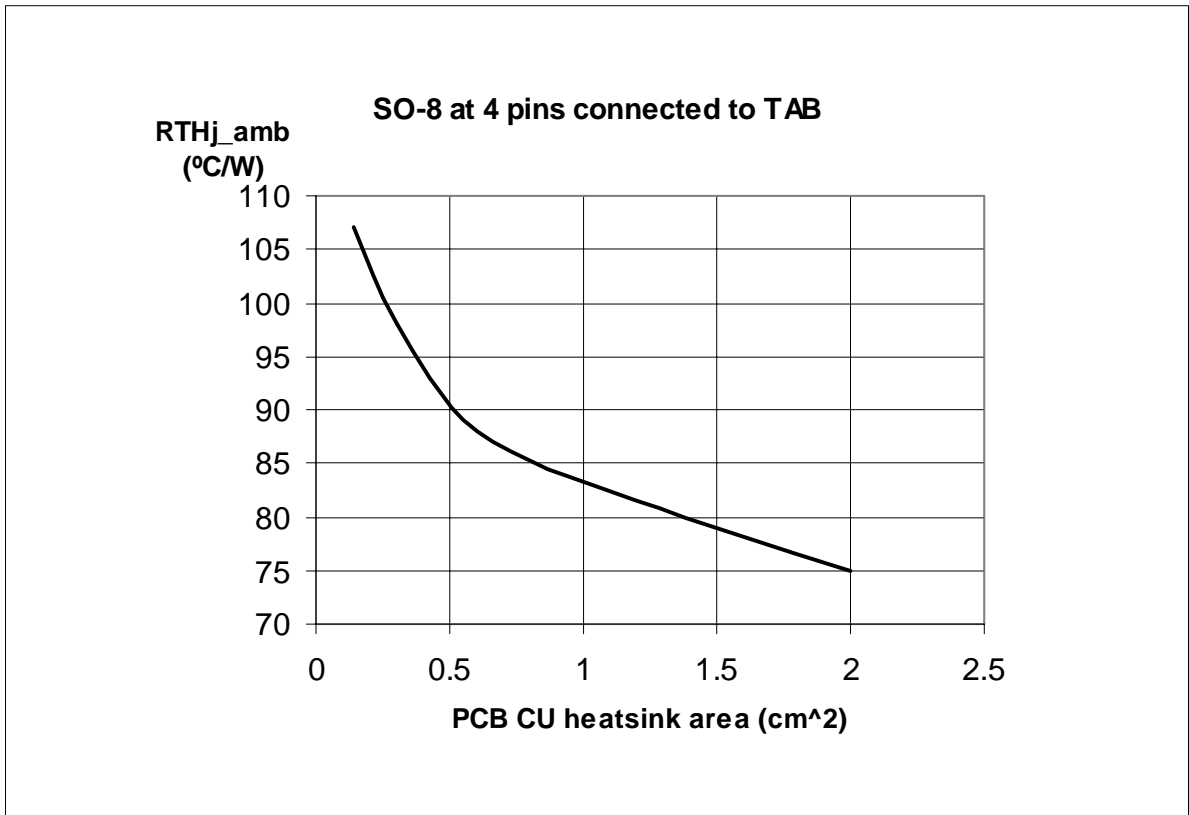

D²PAK THERMAL DATA

D²PAK PC Board

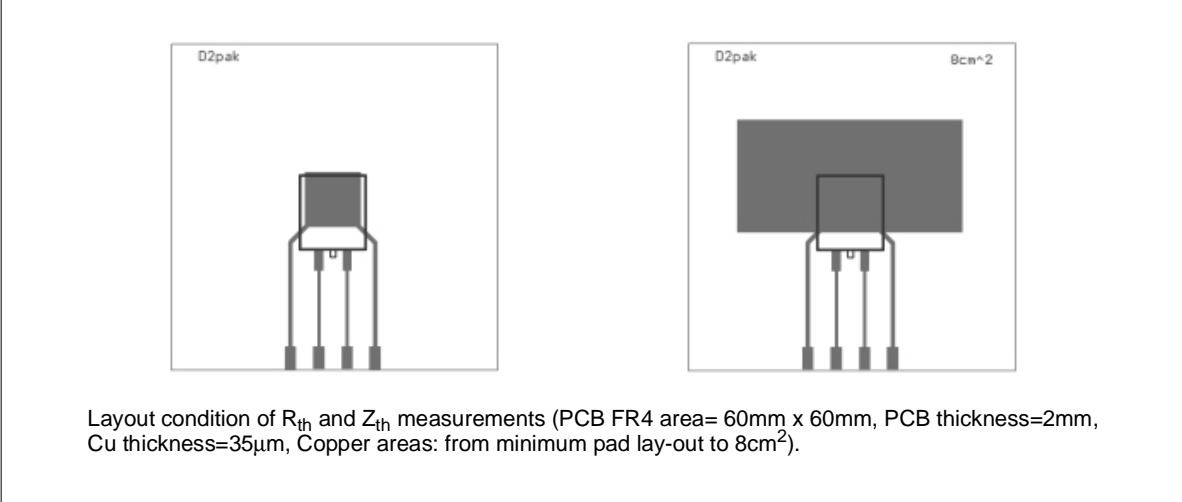

$R_{thj-amb}$ Vs PCB copper area in open box free air condition

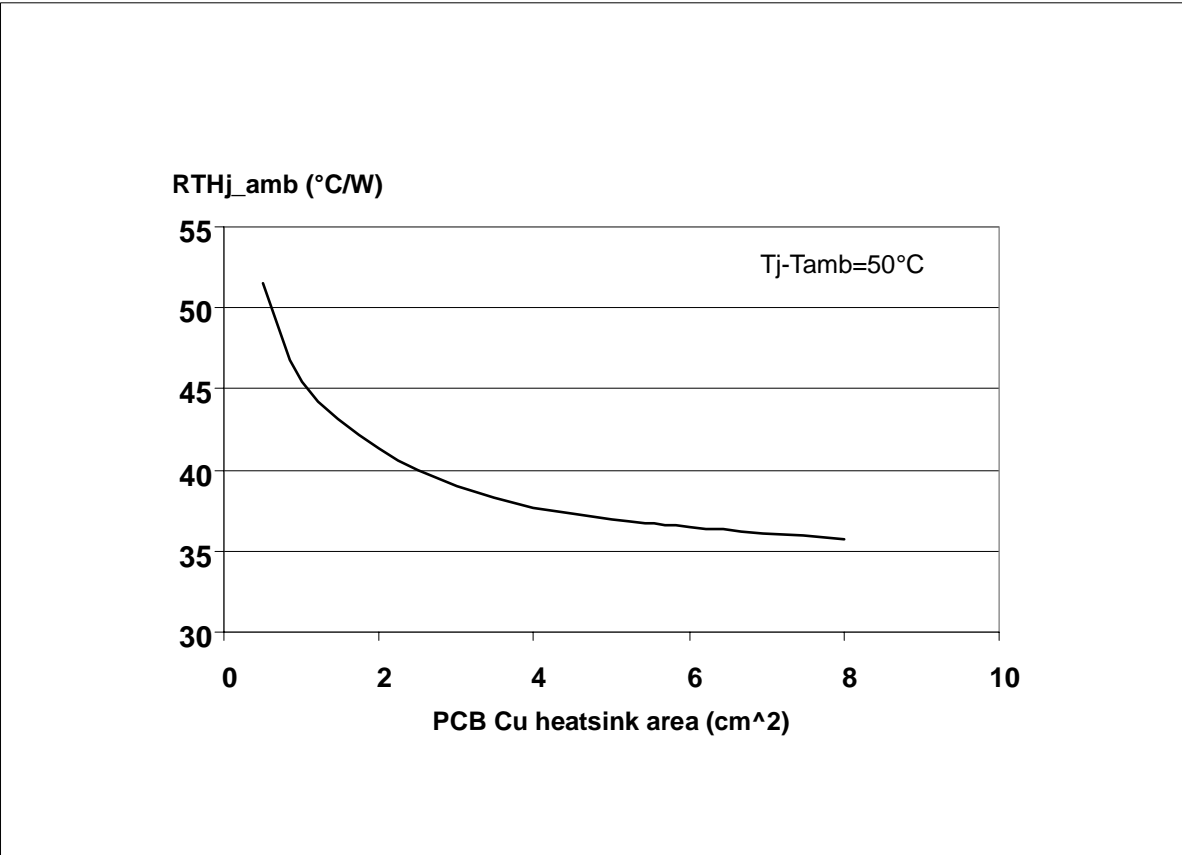

DPAK Thermal Impedance Junction Ambient Single Pulse

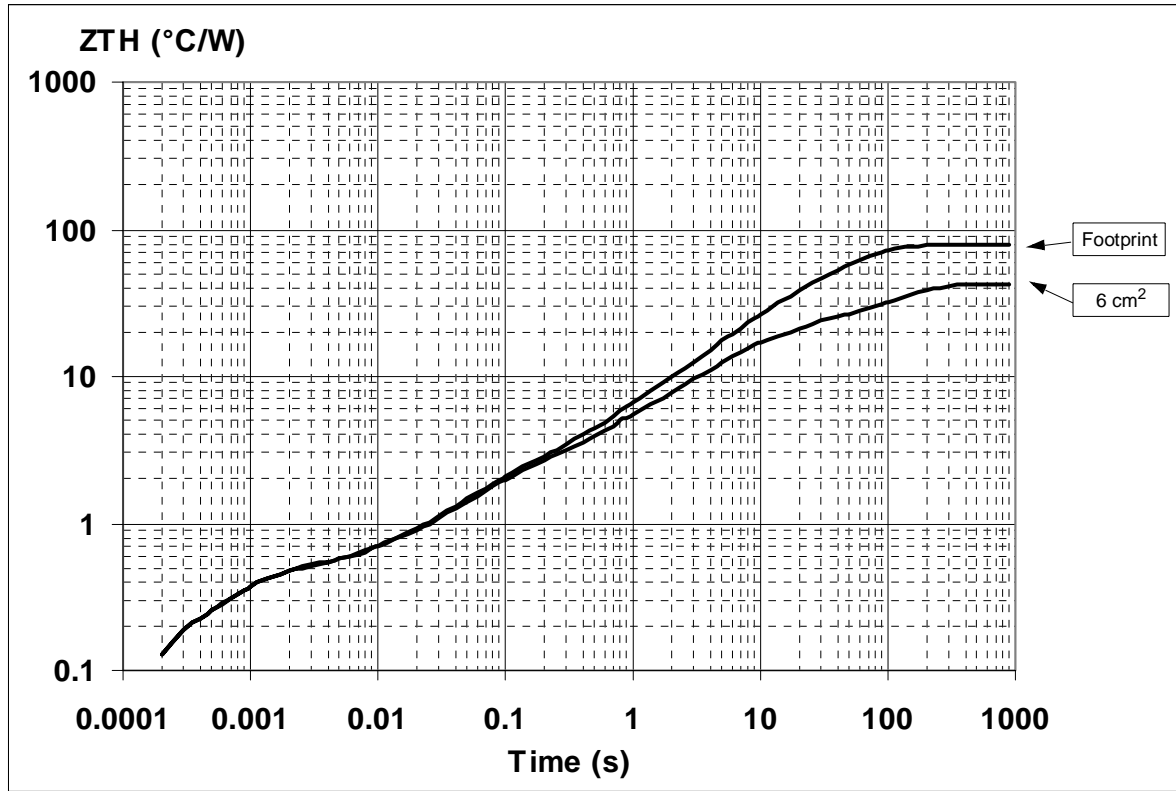

Thermal fitting model of an OMNIFET II in DPAK

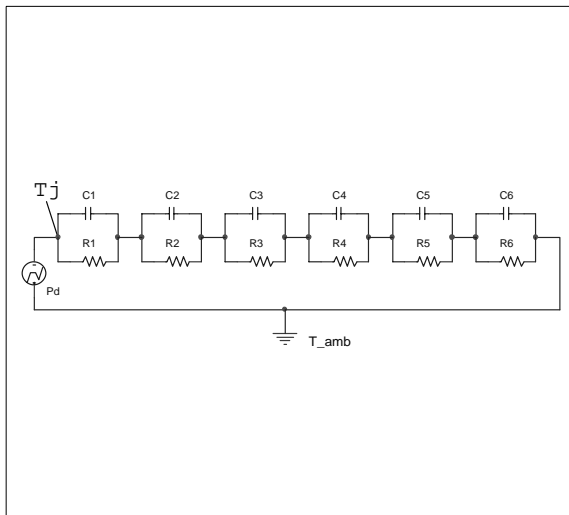

Pulse calculation formula

$$Z_{TH\delta} = R_{TH} \cdot \delta + Z_{THtp}(1 - \delta)$$

where $\delta = t_p/T$

Thermal Parameter

Area/island (cm ²)	Footprint	6
R1 (°C/W)	0.1	
R2 (°C/W)	0.35	
R3 (°C/W)	1.20	
R4 (°C/W)	2	
R5 (°C/W)	15	
R6 (°C/W)	61	24
C1 (W.s/°C)	0.0006	
C2 (W.s/°C)	0.0021	
C3 (W.s/°C)	0.05	
C4 (W.s/°C)	0.3	
C5 (W.s/°C)	0.45	
C6 (W.s/°C)	0.8	5

D²PAK Thermal Impedance Junction Ambient Single Pulse

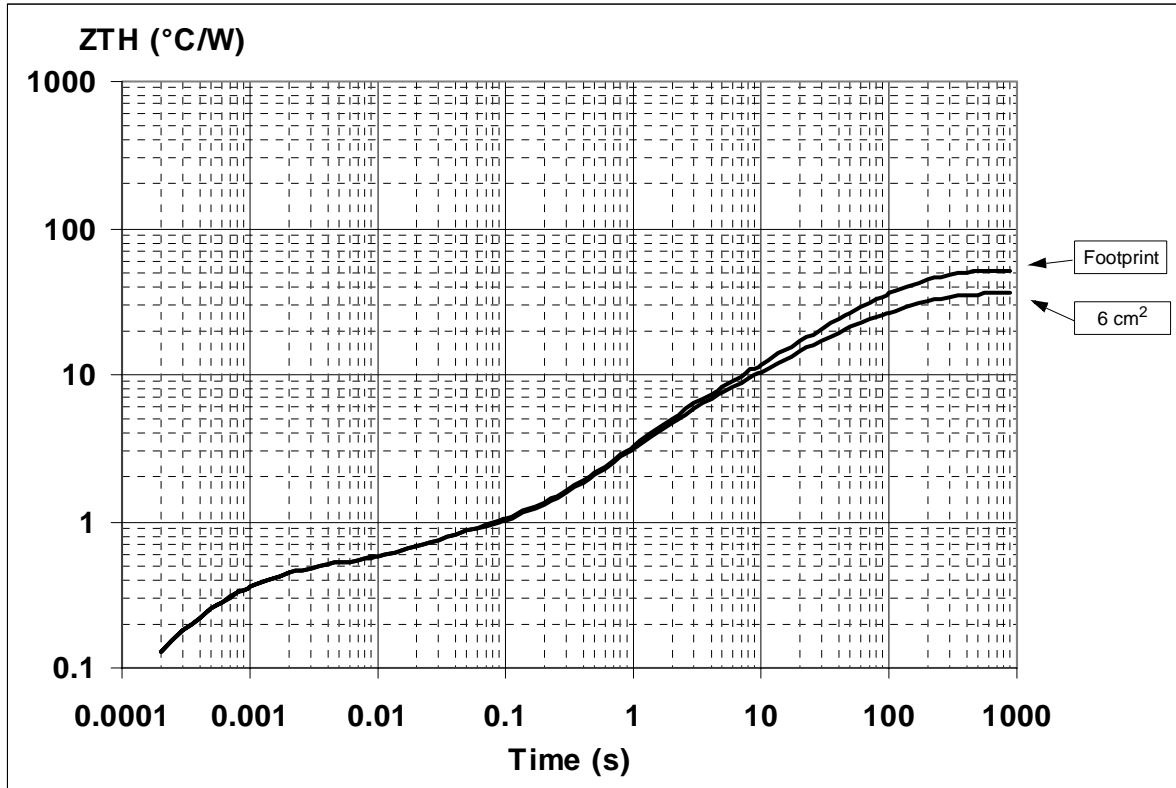

Thermal fitting model of an OMNIFET II in D²PAK

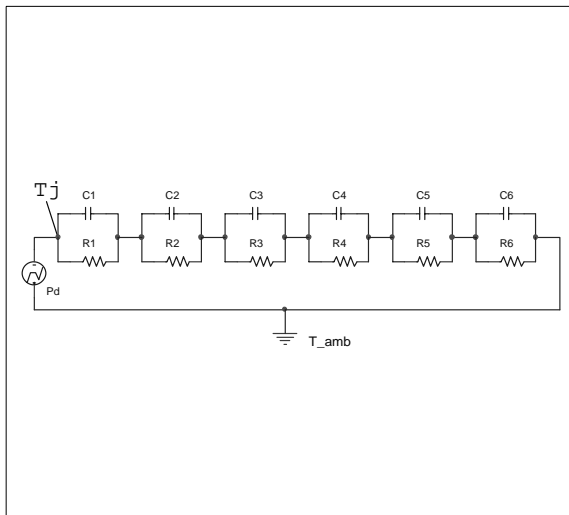

Pulse calculation formula

$$Z_{TH\delta} = R_{TH} \cdot \delta + Z_{THtp}(1 - \delta)$$

where $\delta = t_p/T$

Thermal Parameter

Area/island (cm ²)	Footprint	6
R1 (°C/W)	0.1	
R2 (°C/W)	0.35	
R3 (°C/W)	0.3	
R4 (°C/W)	4	
R5 (°C/W)	9	
R6 (°C/W)	37	22
C1 (W.s/°C)	0.0006	
C2 (W.s/°C)	2.10E-03	
C3 (W.s/°C)	8.00E-02	
C4 (W.s/°C)	0.45	
C5 (W.s/°C)	2	
C6 (W.s/°C)	3	5

TO-251 (IPAK) MECHANICAL DATA

DIM.	mm.			inch		
	MIN.	TYP.	MAX.	MIN.	TYP.	MAX.
A	2.2		2.4	0.086		0.094
A1	0.9		1.1	0.035		0.043
A3	0.7		1.3	0.027		0.051
B	0.64		0.9	0.025		0.031
B2	5.2		5.4	0.204		0.212
B3			0.85			0.033
B5		0.3			0.012	
B6			0.95			0.037
C	0.45		0.6	0.017		0.023
C2	0.48		0.6	0.019		0.023
D	6		6.2	0.236		0.244
E	6.4		6.6	0.252		0.260
G	4.4		4.6	0.173		0.181
H	15.9		16.3	0.626		0.641
L	9		9.4	0.354		0.370
L1	0.8		1.2	0.031		0.047
L2		0.8	1		0.031	0.039

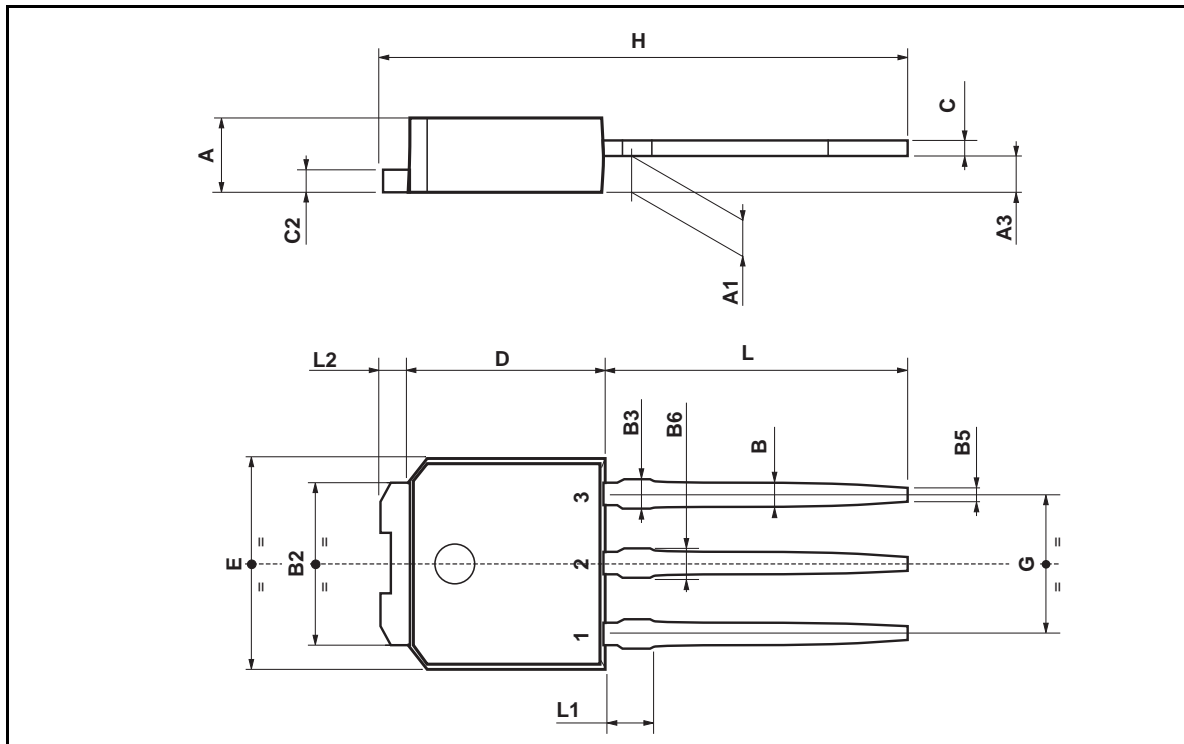

D²PAK MECHANICAL DATA

DIM.	mm.		
	MIN.	TYP	MAX.
A	4.4		4.6
A1	2.49		2.69
A2	0.03		0.23
B	0.7		0.93
B2	1.14		1.7
C	0.45		0.6
C2	1.23		1.36
D	8.95		9.35
D1		8	
E	10		10.4
E1		8.5	
G	4.88		5.28
L	15		15.85
L2	1.27		1.4
L3	1.4		1.75
M	2.4		3.2
R		0.4	
V2	0°		8°

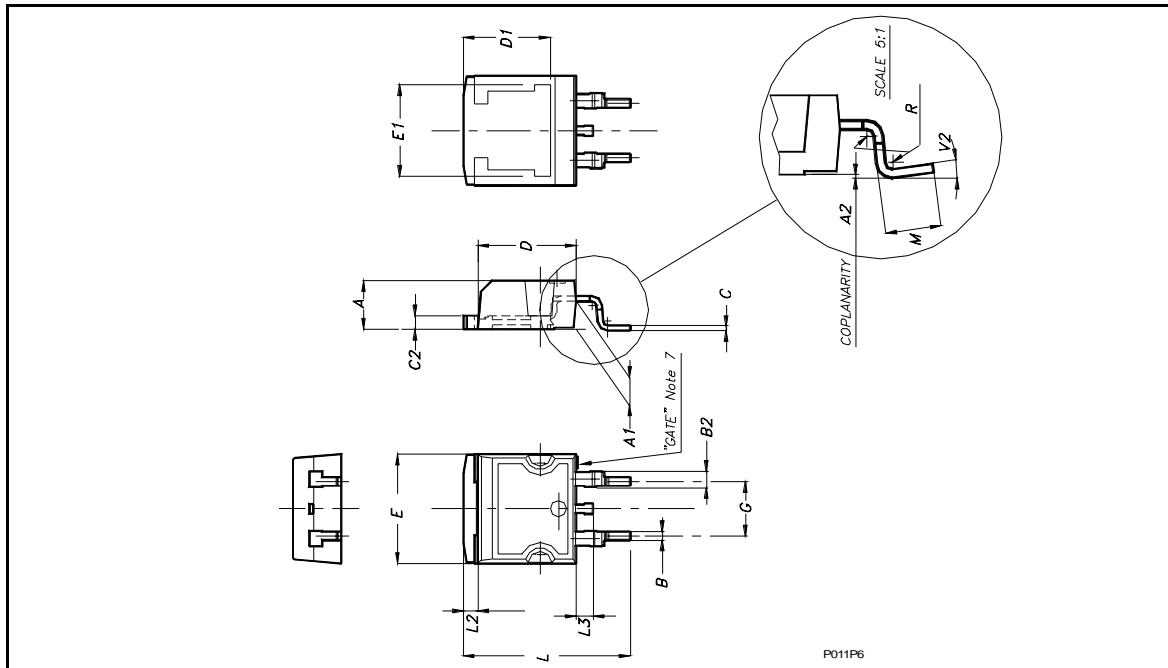

P011P6

TO-252 (DPAK) MECHANICAL DATA

DIM.	mm.		
	MIN.	TYP	MAX.
A	2.20		2.40
A1	0.90		1.10
A2	0.03		0.23
B	0.64		0.90
B2	5.20		5.40
C	0.45		0.60
C2	0.48		0.60
D	6.00		6.20
D1		5.1	
E	6.40		6.60
E1		4.7	
e		2.28	
G	4.40		4.60
H	9.35		10.10
L2		0.8	
L4	0.60		1.00
R		0.2	
V2	0°	8°	
Package Weight	Gr. 0.29		

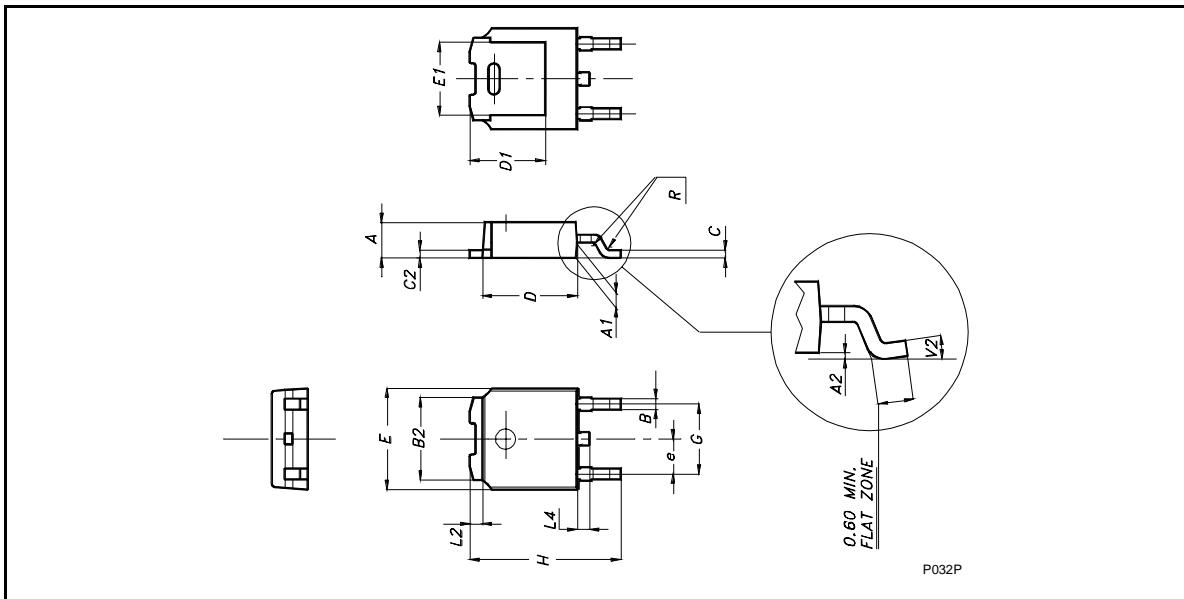

TO-220 MECHANICAL DATA

DIM.	mm.		
	MIN.	TYP	MAX.
A	4.40		4.60
b	0.61		0.88
b1	1.15		1.70
c	0.49		0.70
D	15.25		15.75
E	10		10.40
e	2.40		2.70
e1	4.95		5.15
F	1.23		1.32
H1	6.20		6.60
J1	2.40		2.72
L	13		14
L1	3.50		3.93
L20		16.40	
L30		28.90	
ØP	3.75		3.85
Q	2.65		2.95
Package Weight	1.9Gr. (Typ.)		

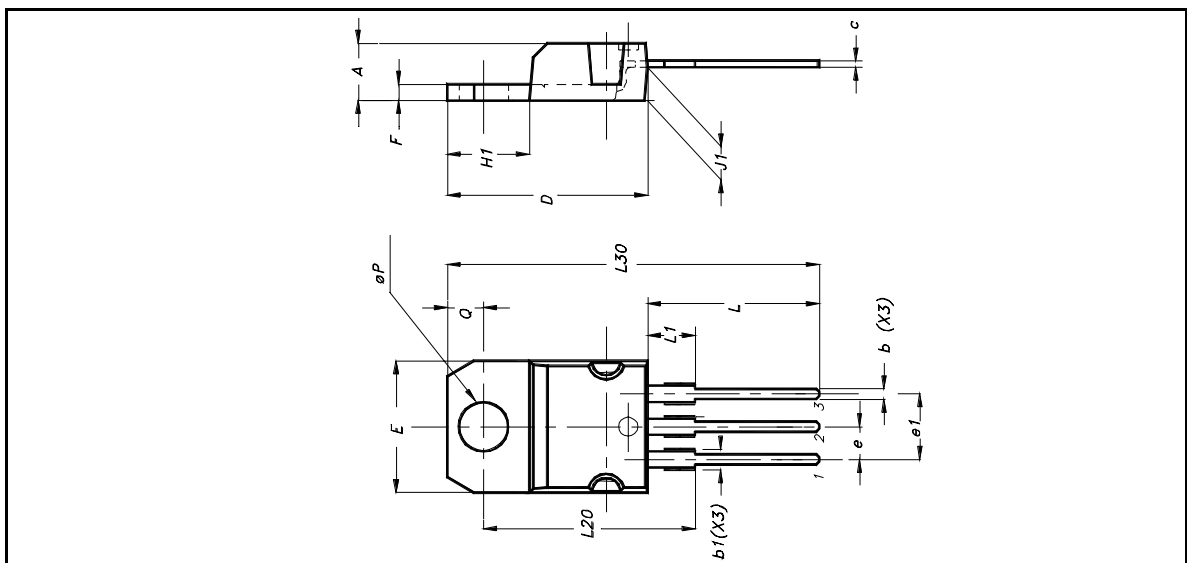

SO-8 MECHANICAL DATA

DIM.	mm.			inch		
	MIN.	TYP.	MAX.	MIN.	TYP.	MAX.
A			1.75			0.068
a1	0.1		0.25	0.003		0.009
a2			1.65			0.064
a3	0.65		0.85	0.025		0.033
b	0.35		0.48	0.013		0.018
b1	0.19		0.25	0.007		0.010
C	0.25		0.5	0.010		0.019
c1	45 (typ.)					
D	4.8		5.0	0.188		0.196
E	5.8		6.2	0.228		0.244
e		1.27			0.050	
e3		3.81			0.150	
F	3.8		4.0	0.14		0.157
L	0.4		1.27	0.015		0.050
M			0.6			0.023
F	8 (max.)					

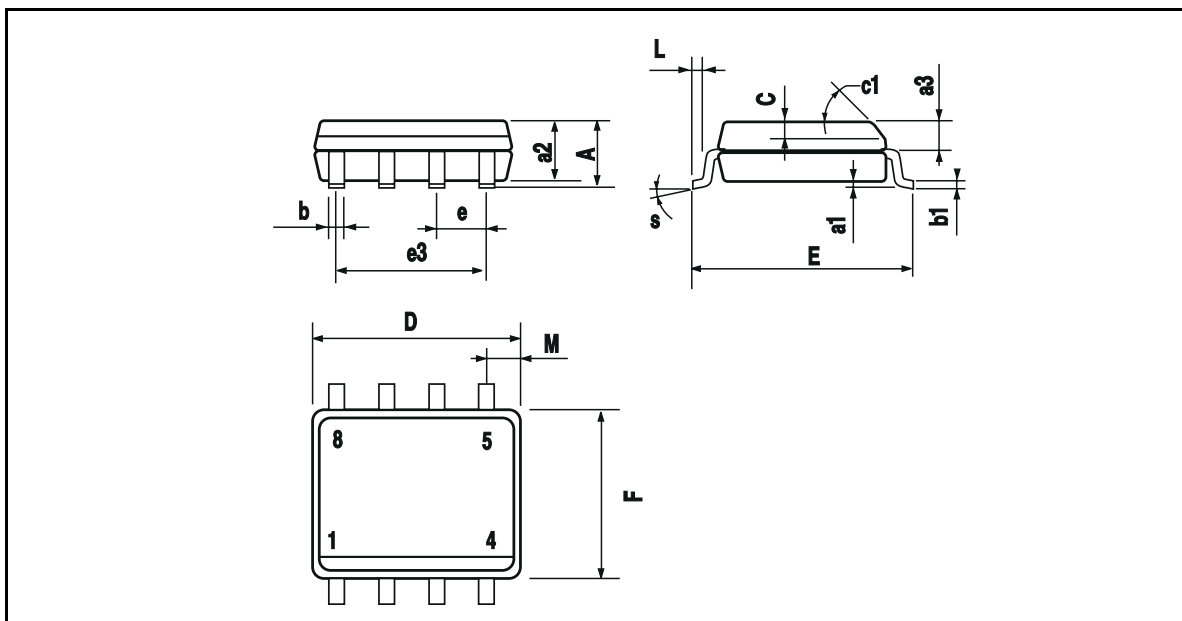

D²PAK FOOTPRINT

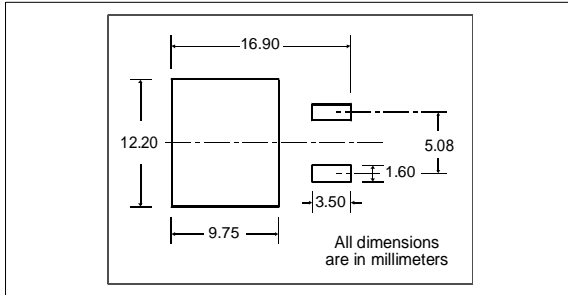

TUBE SHIPMENT (no suffix)

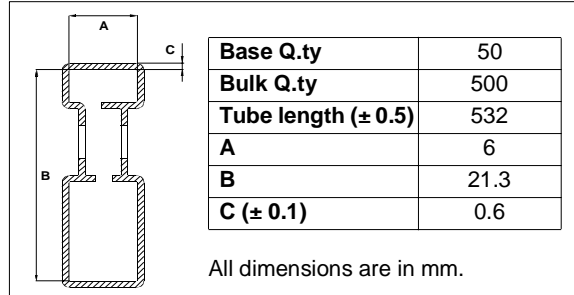

TAPE AND REEL SHIPMENT (suffix "13TR")

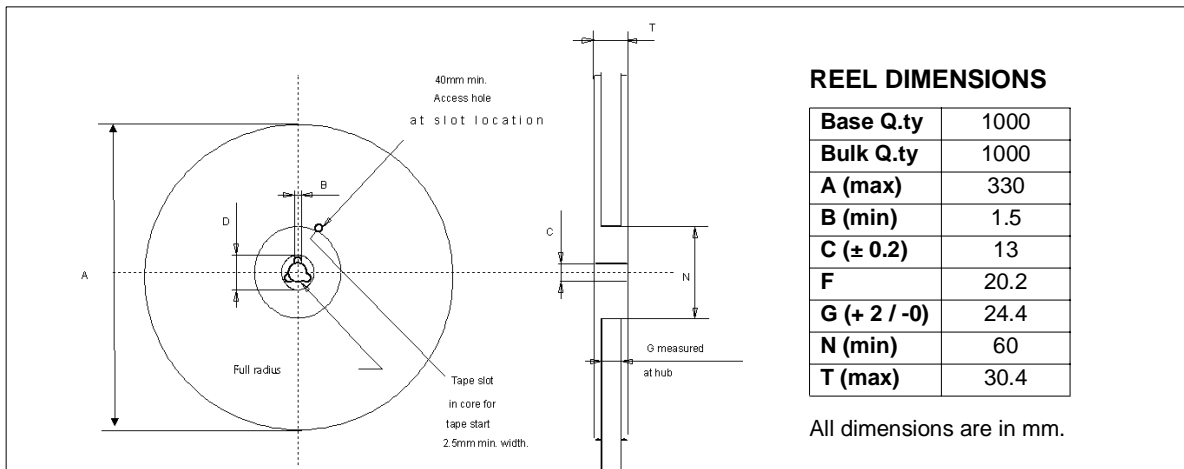

TAPE DIMENSIONS

According to Electronic Industries Association (EIA) Standard 481 rev. A, Feb 1986

Tape width	W	24
Tape Hole Spacing	P0 (± 0.1)	4
Component Spacing	P	16
Hole Diameter	D (± 0.1/-0)	1.5
Hole Diameter	D1 (min)	1.5
Hole Position	F (± 0.05)	11.5
Compartment Depth	K (max)	6.5
Hole Spacing	P1 (± 0.1)	2

All dimensions are in mm.

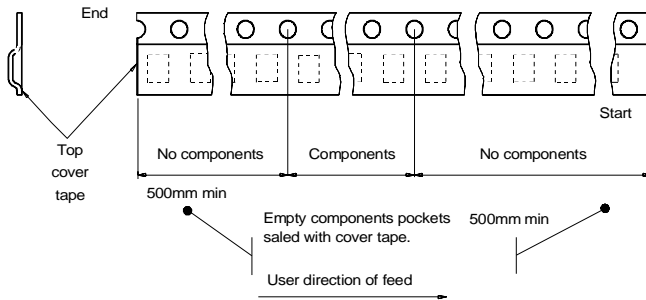
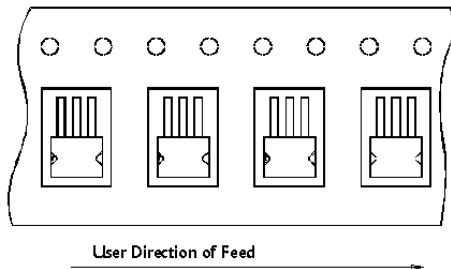
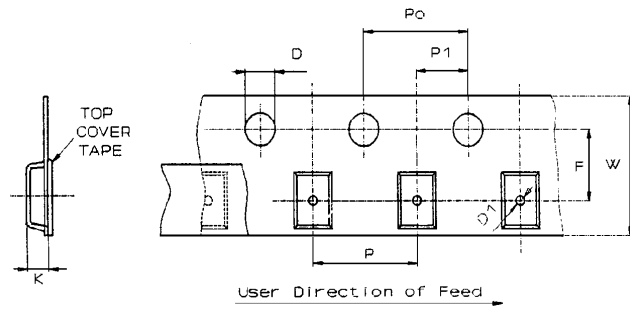

VNB14NV04 / VND14NV04 / VND14NV04-1 / VNP14NV04 / VNS14NV04

DPAK FOOTPRINT

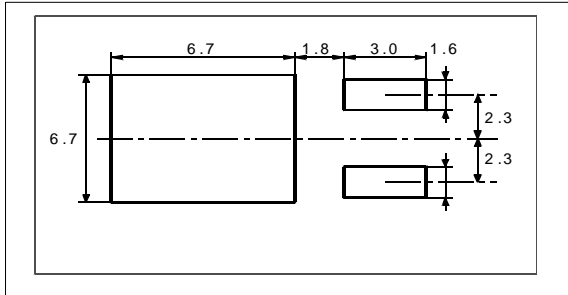

TUBE SHIPMENT (no suffix)

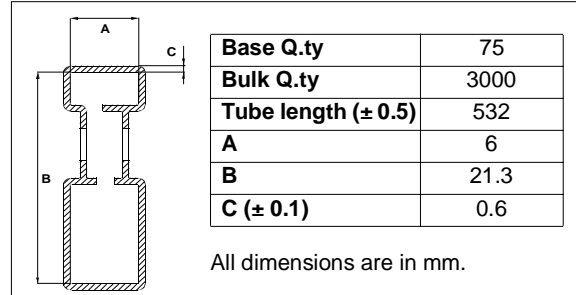

TAPE AND REEL SHIPMENT (suffix "13TR")

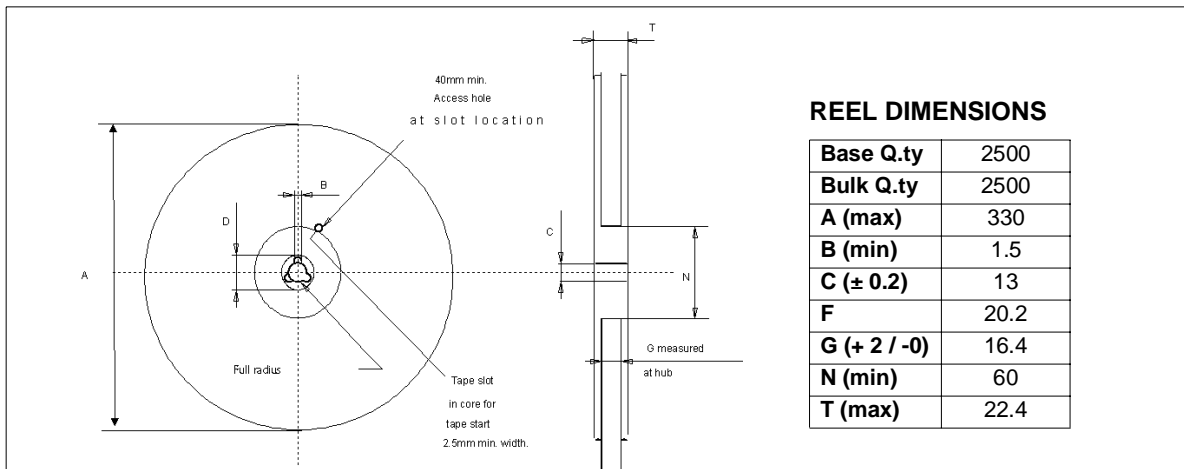

TAPE DIMENSIONS

According to Electronic Industries Association (EIA) Standard 481 rev. A, Feb 1986

Tape width	W	16
Tape Hole Spacing	P0 (± 0.1)	4
Component Spacing	P	8
Hole Diameter	D ($\pm 0.1/-0$)	1.5
Hole Diameter	D1 (min)	1.5
Hole Position	F (± 0.05)	7.5
Compartment Depth	K (max)	6.5
Hole Spacing	P1 (± 0.1)	2

All dimensions are in mm.

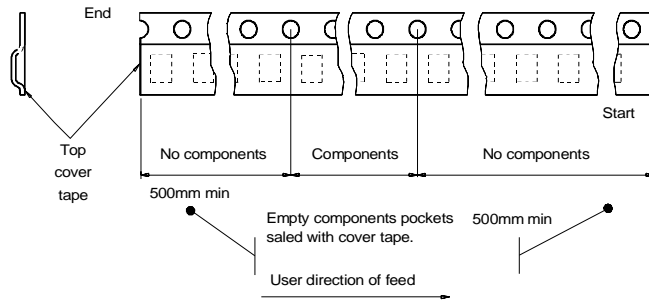
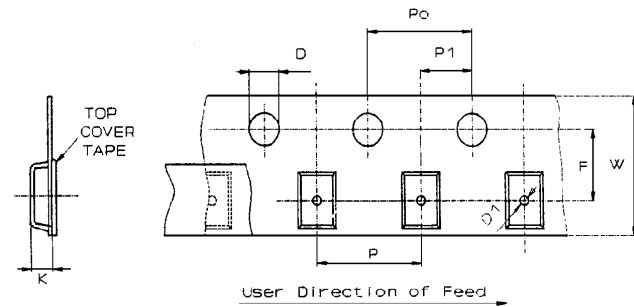
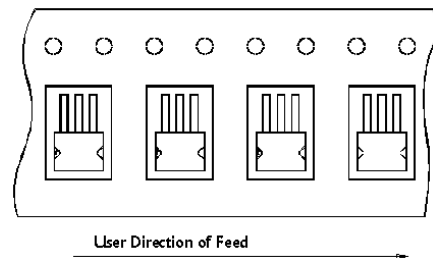

VNB14NV04 / VND14NV04 / VND14NV04-1 / VNP14NV04 / VNS14NV04

SO-8 TUBE SHIPMENT (no suffix)

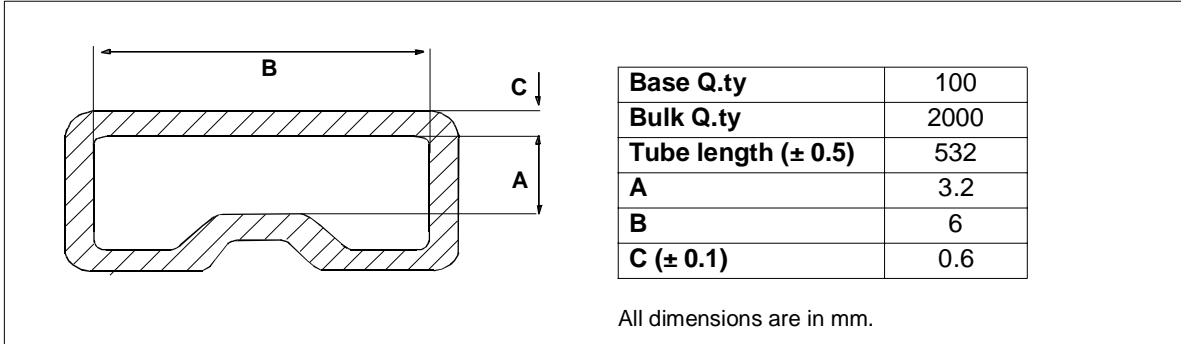

TAPE AND REEL SHIPMENT (suffix "13TR")

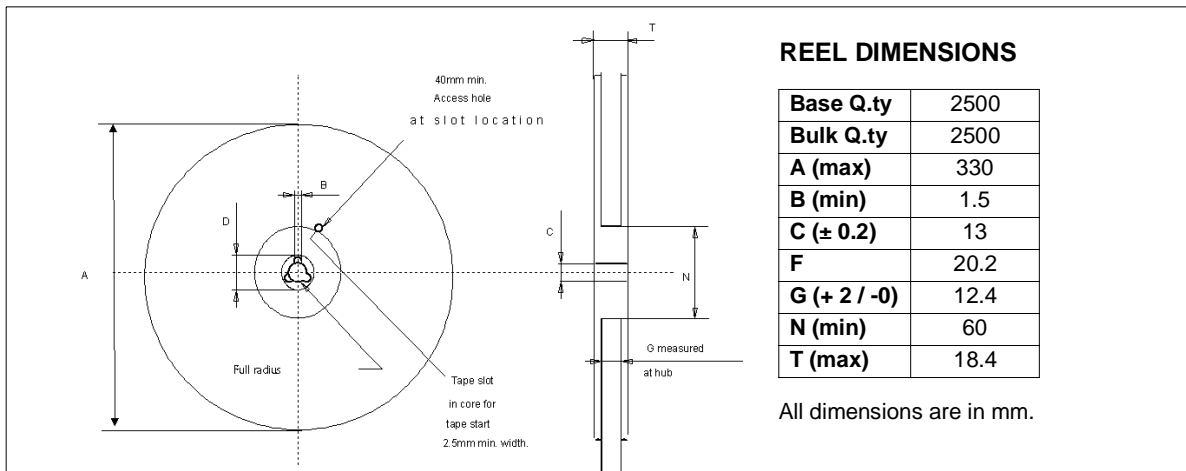

TAPE DIMENSIONS

According to Electronic Industries Association (EIA) Standard 481 rev. A, Feb 1986

Tape width	W	12
Tape Hole Spacing	P0 (± 0.1)	4
Component Spacing	P	8
Hole Diameter	D ($\pm 0.1/-0$)	1.5
Hole Diameter	D1 (min)	1.5
Hole Position	F (± 0.05)	5.5
Compartment Depth	K (max)	4.5
Hole Spacing	P1 (± 0.1)	2

All dimensions are in mm.

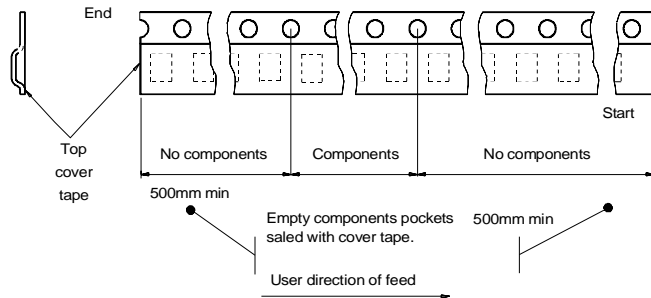
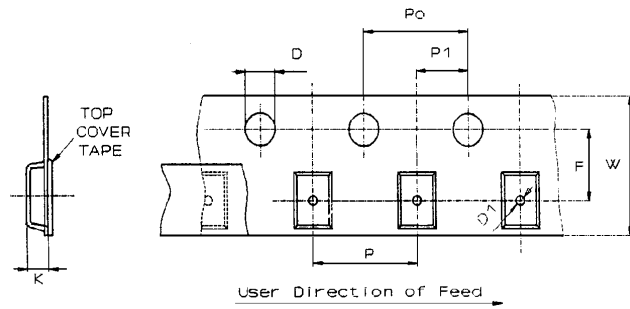
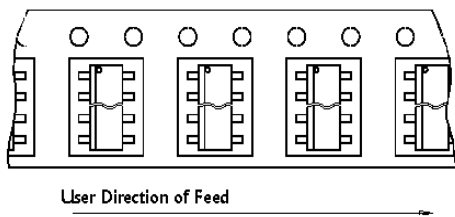

TO-220 TUBE SHIPMENT (no suffix)

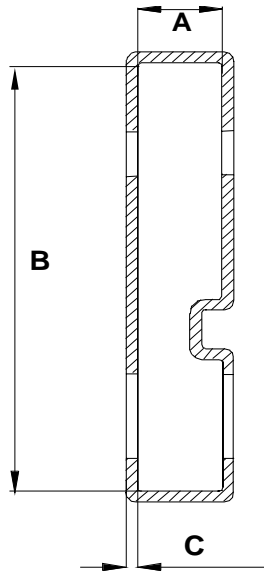

Base Q.ty	50
Bulk Q.ty	1000
Tube length (± 0.5)	532
A	5.5
B	31.4
C (± 0.1)	0.75

All dimensions are in mm.

IPAK TUBE SHIPMENT (no suffix)

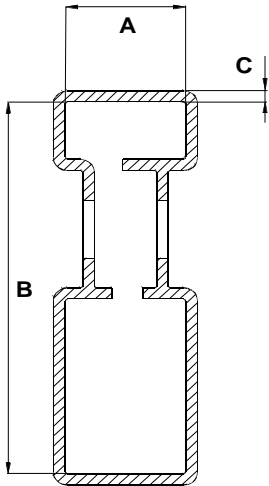

Base Q.ty	75
Bulk Q.ty	3000
Tube length (± 0.5)	532
A	6
B	21.3
C (± 0.1)	0.6

All dimensions are in mm.

MECHANICAL POLARIZATION

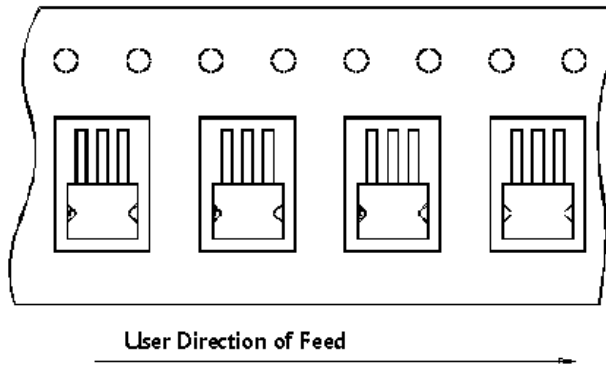

Information furnished is believed to be accurate and reliable. However, STMicroelectronics assumes no responsibility for the consequences of use of such information nor for any infringement of patents or other rights of third parties which may result from its use. No license is granted by implication or otherwise under any patent or patent rights of STMicroelectronics. Specifications mentioned in this publication are subject to change without notice. This publication supersedes and replaces all information previously supplied. STMicroelectronics products are not authorized for use as critical components in life support devices or systems without express written approval of STMicroelectronics.
The ST logo is a trademark of STMicroelectronics

© 2004 STMicroelectronics - Printed in ITALY- All Rights Reserved.

STMicroelectronics GROUP OF COMPANIES

Australia - Brazil - Canada - China - Finland - France - Germany - Hong Kong - India - Israel - Italy - Japan - Malaysia -
Malta - Morocco - Singapore - Spain - Sweden - Switzerland - United Kingdom - U.S.A.

<http://www.st.com>